



High Pressure Sealing Insulated Wire Glands (HPPL)

Conax Technologies manufactures high pressure seals [up to 30,000 psig at 68°F (20°C)] for instrument signal wires. High pressure seals are designed for installation onto the pressure vessel wall using threaded mounting configurations only. High pressure assemblies are factory torqued, so disassembly and reassembly in the field is not recommended.

A 1/2" NPT thread can be added to the assembly cap to allow mounting a terminal box or other type of enclosure. Consult factory for ordering details.

For other types of high pressure applications such as electrode sealing, please consult the factory.

These assemblies feature body and caps constructed from high strength 316SST and a proprietary sealant. HPPL assemblies are provided with Kapton-insulated 26 gauge solid copper wire or 24 gauge thermocouple wire. Standard assemblies include 24" of wire on each side. To order other wire lengths, indicate the desired lengths after the catalog number.

Specifications – High Pressure Assemblies

Catalog Number	Wire Gauge	Number of Wires	Length		Thread Size	Hex Size				Pressure Rating	
			IN	MM		Body IN	Cap IN	Body MM	Cap MM	PSIG	BAR
HPPL14(AM3/S316B)-26-A/(S316B)*-CGL	26	2-7	3.00	76.2	3/4-16	1.250	1.000	31.8	25.4	30,000	2067
HPPL8(AM5/S316B)-26-A/(S316B)*-CGL	26	2-10	3.00	76.2	1 1/8-12	1.250	1.250	31.8	31.8	20,000	2067
HPPL14(AM3/S316B)-24-A/(S316B)*-CGL	24	2-6	3.00	76.2	3/4-16	1.250	1.000	31.8	25.4	20,000	1378
HPPL8(AM5/S316B)-24-A/(S316B)*-CGL	24	2-8	3.00	76.2	1 1/8-12	1.250	1.250	31.8	31.8	20,000	1378

Note: HPPL14 mates with Snap-tite/Autoclave Engineers part type F-375-C. HPPL8 mates with Snap-tite/Autoclave Engineers part type F-562-C.

Tube Connection Dimensions – Autoclave High Pressure FC

Tube Outside	Connection Type	Dimensions inches (mm)							
		A	B	C		D	F	H	
1/4	F250C	33/64 (13.1)	9/16 -18	0.38 (9.7)	0.44 (11.1)	0.17 (4.3)	0.094 (2.4)		
3/8	F375C	11/16 (17.4)	3/4 -16	0.53 (13.5)	0.62 (15.7)	0.26 (6.6)	0.125 (3.2)		
9/16	F562C	1-3/64 (26.6)	1-1/8 -12	0.62 (15.7)	0.75 (19.1)	0.38 (9.7)	0.188 (4.8)		
9/16	F562C40	1-3/64 (26.6)	1-1/8 -12	0.62 (15.7)	0.75 (19.1)	.038 (9.7)	0.250 (6.4)		
5/16	F312C150	37/64 (14.7)	5/8 -18	0.62 (15.7)	1.06 (26.9)	0.25 (6.4)	0.094 (2.4)		

Note: All dimensions are shown for reference only and should not be considered as actual machining dimensions. All threads are manufactured to a class 2A or 2B fit.

* Body side wire length 80" (203.2 cm) maximum. Consult factory for longer lengths.

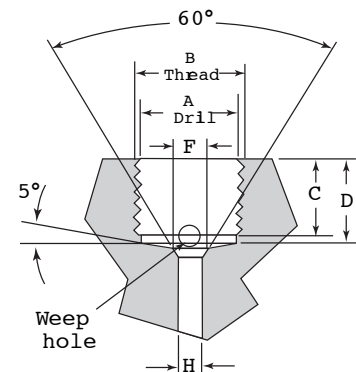

Example: HPPL14(AM3/S316B)-26-A/(S316B)2-CGL, 30/45



High Pressure Sealing Electrode Glands (HPEG)

Conax Technologies manufactures high pressure seals [up to 20,000 psig at 68°F (20°C)] for electrode feedthroughs. High pressure seals are designed for installation onto the pressure vessel wall using threaded mounting configurations only. High pressure assemblies are factory torqued, so disassembly and reassembly in the field is not recommended.

These assemblies feature body and caps constructed from high strength 316SST and a proprietary sealant. Each unit has a stepped electrode. The larger diameter electrode is on the body side. SST nuts and washers are used for nickel and stainless steel and brass is used for copper.

The electrode is copper (CU), stainless steel (SS) or nickel (NI).

The voltage rating is 2000VDC. All prices include a pressure test at 68°F (20°C)].

Specifications – High Pressure Assemblies

Catalog Number	Thread Size	Max Amperage Rating		
		CU	SS	NI
HPEG(ASM5/S316)-093/187-A-CU-V	.8125-16UNF-2A	20	10	3
HPEG(ASM7/S316)-187/312-A-CU-V	.750-14NPSM	60	25	9

Note: HPEG with ASM5 mates with Snap-tite/Autoclave Engineers part type SF562CX10.
HPEG with ASM7 mates with Snap-tite/Autoclave Engineers part type SF750CX10.

Tube Connection Dimensions – Autoclave Medium Pressure SFCX

Tube Outside	Connection Type	Dimensions inches (mm)							
		A	B	C	D	F	H		
1/4	SF250CX20	25/64 (9.9)	7/16 -20	0.28 (7.1)	0.50 (12.7)	0.19 (4.8)	0.109 (2.8)		
3/8	SF375CX20	33/64 (13.1)	9/16 -18	0.38 (9.7)	0.62 (15.7)	0.31 (7.9)	0.203 (5.2)		
9/16	SF562CX10	3/4 (19.1)	13/16 -16	0.44 (11.1)	0.75 (19.1)	0.50 (12.7)	0.359 (9.1)		
3/4	SF750CX10	61/64 (24.2)	3/4 -14	0.50 (12.7)	0.94 (23.9)	.062 (15.7)	0.516 (13.1)		
1	SF1000CX10	1-19/64 (32.9)	1-3/8 -12	0.81 (20.5)	1.31 (33.3)	0.88 (22.4)	0.688 (17.5)		
1	SF1000CX43	1-19/64 (32.9)	1-3/8 -12	0.81 (20.5)	1.31 (33.3)	0.88 (22.4)	0.438 (11.1)		

Note: All dimensions are shown for reference only and should not be considered as actual machining dimensions.
All threads are manufactured to a class 2A or 2B fit.

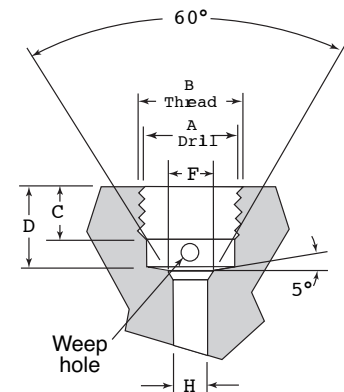

PL SERIES