

Sealing Gland Assembly Instructions

Split Packing Gland Series

Models: PGS

CAUTION: Conax Technologies sealing glands should be installed by suitably qualified personnel in accordance with relevant safety rules and with proper regard to safe working practices.

Conax Technologies sealing glands have lubricant applied at the factory. Substitution of factory-supplied lubricant will affect seal integrity. Lubrication prevents thread galling and minimizes friction between mating metallic components to maximize sealing gland performance when a catalog-specified torque is applied. Weld mount models should be relubricated after the body is welded in place. If the gland has been cleaned before assembly, it should also be relubricated prior to assembly.

Lubricant should be used any time a sealing gland assembly is opened for replacement or adjustment of the probe(s), wires or sealant. By re-lubricating the gland body threads and load bearing surface of the cap, proper load transfer (sealant compression) can be achieved. See page 16 for lubrication instructions.

Conax Technologies recommends the use of thread sealant tape or dopant on NPT threads during installation of the gland to the vessel.

Flange mounted glands should be assembled prior to mounting to the vessel.

A Note on B Caps:

When using a sealing gland assembly with a B Cap, it is sometimes easy to confuse which NPT thread screws into the process side. If installed backwards, leakage will occur between the cap and body straight thread.

A hex notch (as shown below) has been added to the cap to simplify identification. When properly installed, the hex notch will appear on the non-process side of the assembly.

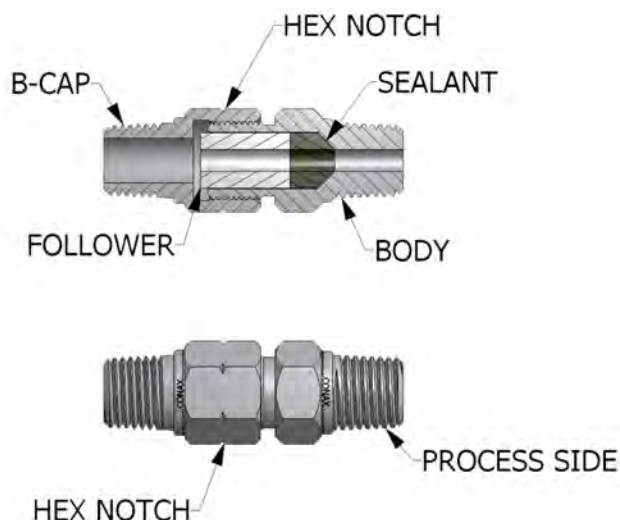

Please Note: Glands previously purchased may have "Conax" engraved on a cap hex surface in lieu of the hex notch. When properly installed the lettering will appear on the non-process side of the assembly (the cap). Please consult the factory with any questions before installing.

Guidelines for Sealant Replacement

Conax Technologies recommends the following procedures to facilitate sealant replacement:

1. Ensure that all system pressurization has been removed before beginning sealant replacement.
2. Untorque and remove the sealing gland cap.
3. Remove the follower and sealant. Depending on the application, the element may also need to be removed.

Follower Removal: Tight manufacturing tolerances are used between the follower OD and the bore of the sealing gland body. As the follower is extracted, a vacuum can be created between the follower and sealant, making it difficult to remove the follower by hand. It may be necessary to clamp the exposed portion of the follower with pliers or a similar tool to gain the additional clamping force needed to remove the follower. If this is necessary, take care to avoid damage to the follower.

Sealant Removal: Teflon, Neoprene, and Viton sealants can generally be removed in one piece. Grafoil and Lava Sealants must be removed in multiple pieces, using a rigid "picking" instrument to break apart the sealant. During this process, be careful to avoid damage to the sealing gland body. Deep scratches or gouges may result in potential leak paths during future use of the gland assembly.

4. Thoroughly clean the internal configuration of the sealing gland body with de-ionized water or cleaning alcohol (depending on the application) to remove any sealant residue.
5. Reassemble per applicable assembly instructions.

For Split Glands – PGS Series

For assembly separate from the vessel:

1. Verify that the probe length is sufficient for your desired immersion.
2. Secure the gland body into a vice.
3. Thread the cap over the probe with the female thread facing the process (see diagram).
4. Insert the probe through the body.
5. Assemble the mating halves of the seat around the probe with the concave side facing away from the process.
6. Slide the assembled seat into the body.
7. Be sure you are using the correct sealant for your working pressure and temperature. Assemble the mating halves of the sealant around the probe with the cone facing the process.
8. Slide the assembled sealant into the body.
9. Assemble the mating halves of the follower around the probe with the counterbore facing the cap.
10. Slide the assembled follower into the body.
11. Push on the follower until the sealant and seat are firmly positioned in the gland body.
12. Thread the cap on finger tight.
13. Make the final adjustment of immersion length.
14. Using a torque wrench, tighten the cap to the specified torque (see chart).
15. The assembly is now ready for use. Apply a wrench to the gland body flats – not the cap – for mounting to the vessel.
6. Slide the assembled seat into the body.
7. Be sure you are using the correct sealant for your working pressure and temperature. Assemble the mating halves of the sealant around the probe with the cone facing the process.
8. Slide the assembled sealant into the body.
9. Assemble the mating halves of the follower around the probe with the counterbore facing the cap.
10. Slide the assembled follower into the body.
11. Push on the follower until the sealant and seat are firmly positioned in the gland body.
12. Thread the cap on finger tight.
13. Make the final adjustment of immersion length.
14. Apply a backer wrench to the gland body flats to prevent rotation during torquing.
15. While holding the backer wrench firmly in place, use a torque wrench to tighten the cap to the specified torque (see chart).
16. The assembly is now ready for use.

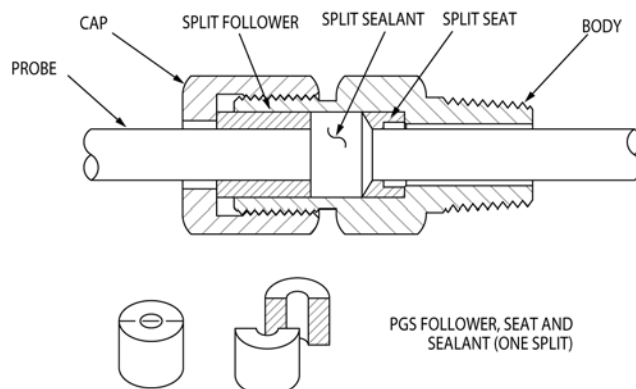

For assembly directly into a vessel:

1. Verify that the probe length is sufficient for your desired immersion.
2. Mount the gland body into the vessel wall. This may be done by threading or welding, depending on the mounting style. When using a weld mount, the gland must be disassembled prior to welding to protect the sealant.
3. Thread the cap over the probe with the female thread facing the process (see diagram).
4. Insert the probe through the body.
5. Assemble the mating halves of the seat around the probe with the concave side facing away from the process.

PGS Series Torque Requirements

Gland Series	Viton		Teflon		Lava		Grafoil	
	(ft-lbs)	(N-m)	(ft-lbs)	(N-m)	(ft-lbs)	(N-m)	(ft-lbs)	(N-m)
PG2S	30-35	40-47	15-20	20-27	40-45	54-61	35-40	47-54
PG4S	55-60	74-81	55-60	74-81	125-140	170-190	90-100	122-136
PG5S	55-60	74-82	90-100	122-136	200-220	272-299	90-100	122-137

Lubricant Application Instructions

Conax Technologies sealing glands have lubricant applied at the factory. Substitution of factory-supplied lubricant will affect seal integrity. Lubrication prevents thread galling and minimizes friction between mating metallic components to maximize sealing gland performance when a catalog-specified torque is applied. Lubrication should be used any time a sealing gland assembly is opened for replacement or adjustment of the probe(s), wires or sealant. By re-lubricating the gland body threads and load bearing surface of the cap, proper load transfer (sealant compression) can be achieved.

Lubricant kits are available from Conax Technologies in convenient, single application, disposable packages with the applicator included. Conax Technologies recommends use of this lubricant to ensure gland performance.

Hex-Style Sealing Glands MK Series

1. Apply a small amount of lubricant, a tear drop equivalent, in two to three places, equally spaced, to the ferrule top. Refer to Figure 1.
2. Apply a single line of lubricant to the full length of the straight thread on the cap. Refer to Figure 1.
3. Assemble the sealing gland per MK sealing gland instructions.

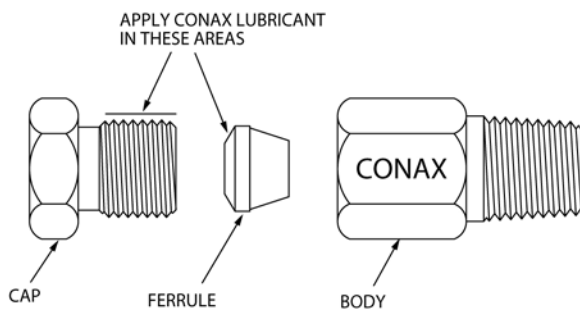

Figure 1

PG, MHM, MHC, TG, PL, EG, EGT, SPG, DSPG, PGS and BSWS Series

1. Apply a small amount of lubricant, tear drop equivalent, in two to three places, equally spaced, to the top of the follower. Do not allow the lubricant to directly contact the sealant or the elements you are sealing. Refer to Figure 2.

2. Apply a single line of lubricant to the full length of the straight thread on the gland body. Refer to Figure 2.
3. Assemble the sealing gland per applicable sealing gland instructions.

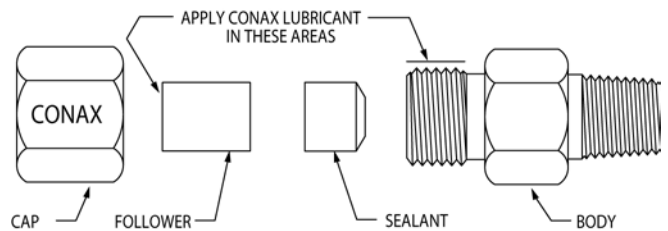

Figure 2

Flange-Cap Style Sealing Glands PG, MHM, EG and EGT Series

1. Apply a small amount of lubricant, tear drop equivalent, in two to three places, equally spaced, to the underside of the hex cap screw on each of the six (6) hex cap screws. Do not allow the lubricant to directly contact the sealant or the elements you are sealing. Refer to Figure 3.
2. Apply a single line of lubricant to the full thread length on each of the six (6) hex head screws. Refer to Figure 3.
3. Assemble the sealing gland. Apply torque per applicable gland chart.

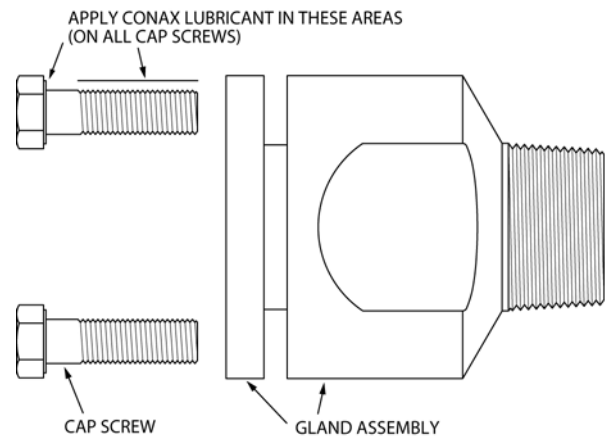

Figure 3

CAUTION: Lubricant may cause mild eye irritation. Do not use for lubrication of aluminum or magnesium parts.

This product is not an OSHA hazardous material, as defined in 29 CFR 1910.120. This product contains CAS #9002839, Ethene, chlorotrifluoro-homopolymer. 24-Hour Emergency Phone 1-800-733-3665. HMIS Rating System: Health 0, Flammability 0, Reactivity 1. For industrial use only.



2300 Walden Avenue • Buffalo, New York 14225
FAX: 716-684-7433 • Phone: 716-684-4500 • 1-800-223-2389
e-mail: info@conaxtechnologies.com

www.conaxtechnologies.com

Conax Technologies is a registered trademark of Conax Technologies. Teflon is a registered trademark of E.I. DuPont de Nemours Company. Viton is a registered trademark of Dupont Dow Elastomers, LLC. Grafoil is a registered trademark of UCAR International, Inc. PEEK is a registered trademark of Victrex plc.

