

HLPL Hazardous Location Power Lead Feedthrough



HL SERIES ▲
HLPL SERIES

CSA™ Certified in the U.S. and Canada with a Pressure Rating of 725 PSIG

HLPL power lead fittings provide pressure/vacuum sealing on Kapton™ insulated solid leadwires. HLPL glands seal against gasses and liquids, resist element movement under pressure, and are certified to:

- ATEX, Ex db IIC Gb/Ex eb IIC Gb/Ex ta IIIC Da/Ex II 2G IITD
-40 °C ≤ Ta ≤ 200 °C
- IECEx, Ex db IIC T3 Gb/EX eb IIC T3 Gb/Ex ta IIIC T200 °C Da; -40 °C ≤ Ta ≤ 200 °C

Ingress Protection (IP): 66, 67 and 68 (5 meters for 1 hour)

HLPL Features

- Pressure rated to 1500 PSI max, NPT threads only
- Suitable for gas or liquid
- GraFoil™ sealant
- Teflon™ sleeves to protect wires from damage as they exit either end of feedthrough
- 316/316L SST body and 303 SST B cap, different SST grades to minimize potential galling issues
- Supplied with 18" (minimum) leads on both sides, contact factory for longer lengths
- Additional mounting options may be applied per specific customer application. Consult factory for details.

Catalog Numbering System

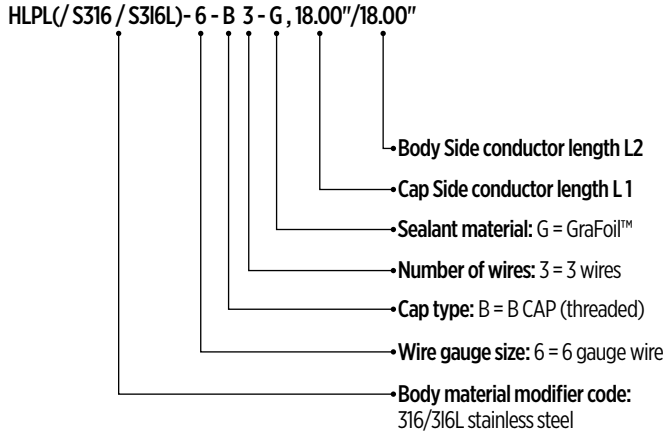

Example:

HLS 4 - 14 A1 - B 3 - G - XX / XX (without conductors)



Specifications

HLPL Series			
Description	Number of Conductors	Standard NPT (Body and "B" Cap)	Amperage Rating Per Wire
HLPL-24-XX-G, XX/XX	2, 4, OR 6	.500-14 NPT	7
	8 OR 12	.750-14 NPT	
HLPL-20-XX-G, XX/XX	2, 3 OR 4	.500-14 NPT	9
	6 OR 8	.750-14 NPT	
	18	.750-14 NPT	
HLPL-18-XX-G, XX/XX	2, 3 OR 4	.500-14 NPT	13
	6 OR 8	.750-14 NPT	
	10 OR 12	.750-14 NPT	
HLPL-16-XX-G, XX/XX	2, 3 OR 4	.500-14 NPT	17
	6 OR 8	.750-14 NPT	
	10 OR 12	.750-14 NPT	
HLPL-14-XX-G, XX/XX	2	.500-14 NPT	24
	3 OR 4	.500-14 NPT	
	6 OR 8	.750-14 NPT	
	10 OR 12	.750-14 NPT	
HLPL-12-XX-G, XX/XX	2, 3, 4 OR 6	.750-14 NPT	30
HLPL-10-XX-G, XX/XX	2, 3 OR 4	.750-14 NPT	40
HLPL-8-XX-G, XX/XX	2	.750-14 NPT	55
	3	.750-14 NPT	
HLPL-6-XX-G, XX/XX	3	.750-14 NPT	60

HPPL High Pressure Sealing Assemblies up to 30,000 PSIG



Conax Technologies manufactures high pressure seals [up to 30,000 PSIG at 68 °F (20 °C)] for instrument signal wires. High pressure seals are designed for installation onto the pressure vessel wall using threaded mounting configurations only. High pressure assemblies are factory torqued, so disassembly and reassembly in the field is not recommended.

These assemblies feature body and caps constructed from high strength 316 SST standard and a proprietary sealant. HPPL assemblies are provided with Kapton™-insulated 26 gauge solid copper wire or 24 gauge

thermocouple wire. Standard assemblies include 24" of wire on each side. To order other wire lengths, indicate the desired lengths after the catalog number.

A 1/2" NPT thread can be added to the assembly cap to allow mounting a terminal box or other type of enclosure. Consult factory for ordering details.

For other types of high pressure applications such as electrode sealing, please consult the factory.

HLPL SERIES ▲
HPPL SERIES

HPPL Series Catalog Number	Wire Gauge	Number of Wires	Length		Thread Size	Hex Size				Pressure Rating	
			IN	MM		Body IN	Cap IN	Body MM	Cap MM	PSIG	BAR
HPPL14(AM2/S316B)-26-A(/S316B)*-CGL	26	2 - 4	2.89	73.4	9/16-18	1.00	1.00	25.4	25.4	30,000	2,067
HPPL14(AM3/S316B)-26-A(/S316B)*-CGL	26	2 - 7	3.00	76.2	3/4-16	1.25	1.00	31.8	25.4	30,000	2,067
HPPL8(AM5/S316B)-26-A(/S316B)*-CGL	26	2 - 10	3.00	76.2	1-1/8-12	1.25	1.25	31.8	31.8	20,000	1,378
HPPL14(AM3/S316B)-24-A(/S316B)*-CGL	24	2 - 6	3.00	76.2	3/4-16	1.25	1.00	31.8	25.4	20,000	1,378
HPPL8(AM5/S316B)-24-A(/S316B)*-CGL	24	2 - 8	3.00	76.2	1-1/8-12	1.25	1.25	31.8	31.8	20,000	1,378

Feedthrough Connection Port Dimensions—Autoclave Engineers FC Port

Tube OD	AE Port Type	Conax Designation	Dimensions inches (mm)					
			A	B	C	D	F	H
1/4	F250C	AM2	33/64 (13.1)	9/16-18	0.38 (9.7)	0.44 (11.1)	0.17 (4.3)	0.094 (2.4)
3/8	F375C	AM3	11/16 (17.4)	3/4-16	0.53 (13.5)	0.62 (15.7)	0.26 (6.6)	0.125 (3.2)
9/16	F562C	AM5	1-3/64 (26.6)	1-1/8-12	0.62 (15.7)	0.75 (19.1)	0.38 (9.7)	0.188 (4.8)
9/16	F562C40	AM5	1-3/64 (26.6)	1-1/8-12	0.62 (15.7)	0.75 (19.1)	0.38 (9.7)	0.250 (6.4)

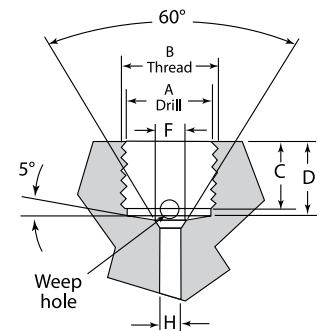

Note: All dimensions are shown for reference only and should not be considered as actual machining dimensions. All threads are manufactured to a class 2A or 2B fit.

* Body side wire length 80" (203.2 cm) maximum. Consult factory for longer lengths.

— Wire Length in inches, Cap Side
— Wire Length in inches, Body Side

Example: HPPL14(AM3/S316B)-26-A(/S316B)2-CGL, 30/45

HPEG High Pressure Sealing Assemblies up to 20,000 PSIG



HPPL SERIES ▲
HPEG SERIES

Conax Technologies manufactures high pressure seals [up to 20,000 PSIG at 68 °F (20 °C)] for electrode feedthroughs. High pressure seals are designed for installation onto the pressure vessel wall using threaded mounting configurations only. High pressure assemblies are factory torqued, so disassembly and reassembly in the field is not recommended.

These assemblies feature body and caps constructed from high strength 316 SST standard and a proprietary sealant.

Each unit has a stepped electrode. The larger diameter electrode is on the body side. SST nuts and washers are used for nickel and stainless steel, and brass is used for copper.

The electrode is copper (CU), stainless steel (SS) or nickel (NI).

The voltage rating is 2000VDC. All HPEG assemblies are factory pressure tested at 68 °F (20 °C).

HPEG Series	Thread Size (IN)	Max Amperage Rating		
		CU	SS	NI
Catalog Number				
HPEG(ASM5/S316)-093/187-A-CU-V	13/16-16UNF-2A	20	10	3
HPEG(ASM7/S316)-187/312-A-CU-V	3/4-14NPSM	60	25	9

Note: HPEG with ASM5 mates with Snap-tite/Autoclave Engineers part type SF562CX10.
HPEG with ASM7 mates with Snap-tite/Autoclave Engineers part type SF750CX10.

Tube Connection Dimensions—Autoclave Medium Pressure SFCX							
Tube OD	Connection Type	Dimensions inches (mm)					
		A	B	C	D	F	H
9/16"	SF562CX10	3/4" (19.1)	13/16-16	0.44 (11.1)	0.75 (19.1)	0.50 (12.7)	0.359 (9.1)
3/4"	SF750CX10	61/64" (24.2)	3/4-14	0.50 (12.7)	0.94 (23.9)	0.62 (15.7)	0.516 (13.1)

Note: All dimensions are shown for reference only and should not be considered as actual machining dimensions. All threads are manufactured to a class 2A or 2B fit.

