

Temperature Sensors & Seals for the Fuel Cell Industry

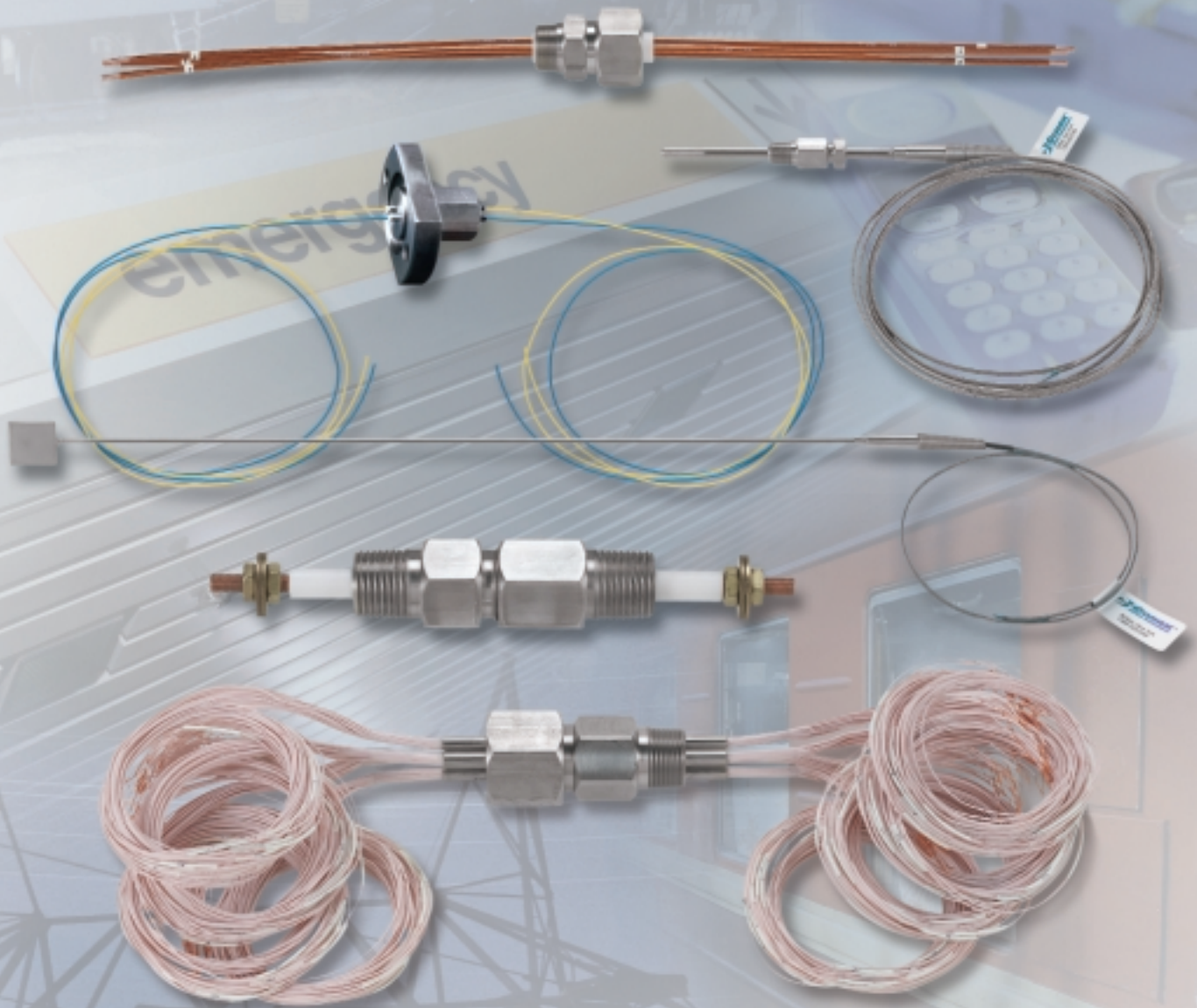

Throughout the world, developers, researchers and experts believe that fuel cell technology is the key to a cleaner, safer and more efficient energy source. Conax Buffalo Technologies is dedicated to supporting the fuel cell industry with effective and reliable means of temperature measurement and pressure/vacuum sealing. **Our products can improve fuel cell efficiency and profitability, and help fuel cell developers get their product to market faster.**

As a key component supplier to the power industry for more than 50 years, Conax Buffalo Technologies has a clear understanding of the need for accurate temperature measurement in energy production. We supply thermocouples, RTDs and thermistors in a nearly endless array of assemblies, with an emphasis on reliable measurement devices that withstand challenging environments such as corrosive gases and acidic electrolyte.

Our sensor assemblies are complemented with our line of pressure/vacuum sealing devices featuring the Conax-designed "soft sealant" technology. We developed this technology and remain the leading manufacturer of this type of sealing device for wires, electrodes and probes. Our seals maintain the containment barrier and provide environmental protection for workers and equipment.

Conax engineers welcome the opportunity to discuss and develop solutions to challenging applications, such as those faced by the fuel cell industry. **We can set the standards of the fuel cell industry for accurate temperature measurement and reliable sealing applications.** If you don't see the exact product you think you need in these pages, please contact a Conax Buffalo Sales Engineer at 800-223-2389 or visit our website at www.conaxbuffalo.com.

TEMPERATURE MEASUREMENT DEVICES FOR CRITICAL APPLICATIONS

Conax temperature sensors provide accurate temperature measurement in temperatures ranging from subzero to 4200° F (2315° C). Whether measuring process temperatures within the fuel cell stack or in the balance of plant, Conax RTD and thermocouple sensor assemblies ensure the accurate measurement needed for maximum operating efficiency. Conax temperature sensors can be used in all common fuel cell technologies: PEM, alkaline, phosphoric acid, molten carbonate and solid oxide fuel cells.



Plug and Jack Assemblies

Conax polarized plug and jack assemblies are available with RTD or thermocouple contacts. Shown with MHM multi-hole metal seal for probe positioning.



Weld Pad Assemblies

Weld pad assemblies facilitate surface temperature measurement. Pads are provided in various configurations to meet application needs.

Sensor Assemblies for Environmental Challenges

Conax sensor assemblies can be provided with various sheath materials to meet environmental challenges. This assembly features a 310SST sheath for corrosion resistance and a stainless steel overbraid for physical protection of leadwires.



Support tube with adjustable mounting fitting and alumina oxide tubewell on this thermocouple assembly provides exceptional resistance to corrosive environments.

"Fuel cells can provide major environmental, energy

FEEDTHROUGHS & SEALING DEVICES

Conax feedthroughs may be used whenever probes, electrodes, wires or sensors pass through a pressure or environmental boundary. They serve as mounting devices and/or environmental seals. The compression of the soft sealant creates a seal on the element, restraining it from moving under pressure or vacuum and barring movement of gas or

liquids along the element. In most cases, the sealants are replaceable and the gland may be loosened and retorqued to allow adjustment in immersion length. Sealing gland assemblies may be customized with special mountings, threads and specifications to meet unique needs.



PG Gland



MK Gland

Tube or Probe Sealing

Conax PG "soft seal" glands are ideal for sealing temperature probes, tubing and cable. They are easily assembled and allow probe re-adjustment.

Midlock glands (MK) use a stainless steel ferrule as the method of sealing.



TG Gland

Bare Wire Sealing

Transducer glands (TG) provide pressure or vacuum sealing of solid bare wire transducers and solid conductors. TG glands seal 1 to 16 elements, depending on size.

Single and Double Split Glands Facilitate Installation & Maintenance

PGS, SPG & DSPG glands are used when the process tip is larger than the diameter of the wire or element to be sealed, or in applications where the elements are long and difficult to handle.



SPG Gland

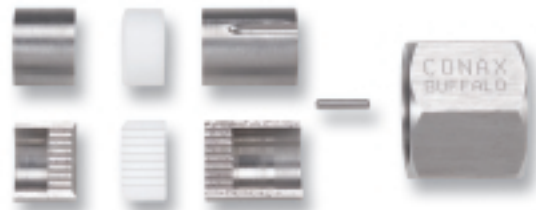

High Density Feedthrough Maximizes Wires Passing Through a Single Port

Conax High Density mechanically sealed feedthrough assemblies permit multiple insulated wires to be installed through a single port. The assembly consists of a stainless steel tube swaged over bundled insulated thermocouple wires or copper wires to form a continuous wire feedthrough. Up to 60 wires (30 thermocouple pairs) can pass through a PG-style feedthrough. When configured with a Conax MHM gland, the high density assembly will accommodate up to 240 conductors (120 pairs) through a single gland.

Multiple Tube or Probe Sealing

Multi-hole ceramic (MHC) and multi-hole metal (MHM) glands allow multiple tubes, probes or sensors of varying diameters to pass through a single gland. Each probe is electrically isolated, and immersion lengths are individually adjustable.



MHM Gland



MHM Gland disassembled





PL Gland, 4 conductor, 14 ga.



PL Gland, 6 conductor, 16 ga.

Sealing on Insulated Leadwire

Power Lead (PL) glands feature Kapton®-insulated copper wire in wire gauges from 20-8 AWG. These are ideal to feed power leads to instrumentation. Also available with 18 AWG thermocouple wire.



EG Gland less conductor

Electrode Sealing

EG and EGT glands serve as bare electrical feedthroughs for higher current and voltage applications. They electrically and/or thermally isolate an electrode or sensor. EGT glands feature a single continuous one-piece Teflon® insulator sealant. EG glands offer a choice of replaceable sealants with ceramic insulators and are available with or without an electrode.



EGT Gland

FIBER OPTIC SENSORS, SEALS & CABLES

Conax has developed the capability to seal on fiber optic cables without the use of epoxies or other significant outgassing materials. These assemblies are designed to seal on virtually any size fiber down to a 400 micron jacket. Multiple fiber optic seal assemblies can be used with Conax multi-hole sealing glands to provide multiple sealed penetrators through a single port. Conax also manufactures rugged, high performance cable assemblies for extreme applications.

Conax offers a line of fiber optic sensors designed to provide accurate and reliable measurement in high temperature applications up to 1650° C. These rugged sensor designs ensure accurate transmission of light energy signals to a digital signal processing unit. Sensor outputs are compatible with common data acquisition systems.



Supporting Fuel Cell Technology – The Power Source of the Future

Conax Buffalo high performance products are currently in use in numerous types of fuel cells, both within the fuel cell stack or in the balance of plant.

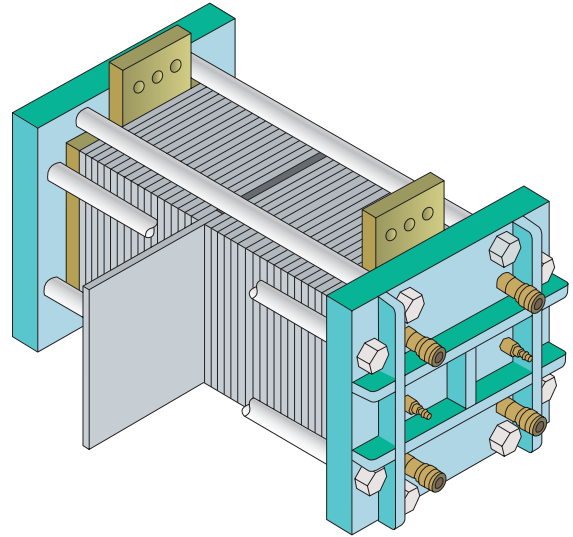

TEMPERATURE MEASUREMENT

Accurate temperature measurement is critical to effective fuel cell operation, whether for testing and validation in development stages or in active production. Conax provides a wide range of sensors from small diameter probes to fit tight spaces between plates with minimal airflow disturbance to assemblies with special materials to resist environmental challenges. Conax temperature sensor assemblies can be used to monitor:

Air Discharge Passage
Fuel Cell Stack
Air Manifold Heater
Oxidizer Exhaust
Anode Exhaust
Cathode Air Inlet

Cathode Discharge
Reformer Water Inlet
ATO Air Inlet
Outdoor Air
Power Terminals

SEALING ASSEMBLIES

Conax's range of "soft sealant" technology pressure/vacuum seals are used throughout the fuel cell as terminals, power lead feedthroughs and bulkhead seals:

Cathode Electrode
Anode Electrode
Cathode Conductor
Anode Conductor
Instrument Wires
Humidity Sensor Lead Seals
Thermocouple or RTD Lead Seals
Thermocouple Sheath Seals

CONAX BUFFALO QUALITY HELPS SET YOUR PRODUCT APART

Quality fuel cells rely on quality component parts. Conax Buffalo Technologies is committed to providing the fuel cell industry with the highest quality products, fast turnaround and on-time delivery. Here are a few reasons why top researchers, fuel cell manufacturers and manufacturers of hydrogen reformers are using Conax Buffalo products:

ISO 9001:2000 Quality Program
Metrology Laboratory to NIST Standards
Pressure Test Capabilities to 100,000 psi

Calibration Laboratory to NIST Standards
Leak Test by Helium Mass Spectrometer
Vibration Test – Unholtz Dickie

CUSTOM DESIGN

Conax Buffalo engineers welcome the opportunity to design special assemblies for challenging applications. Call us today at 800-223-2389 to discuss your application needs.



PROVEN PERFORMERS

Conax Buffalo Technologies is the industry leader in the design and fabrication of temperature sensor assemblies and pressure/vacuum seals for a variety of applications and uses. In the past 50 years, Conax Buffalo has established a reputation as the company to turn to for solutions to your most challenging application needs. Today, we manufacture more than 100,000 standard sensor and seal assemblies in our state-of-the-art production facilities, while our knowledgeable engineering staff continues to break new ground with its custom designs and problem-solving abilities.

We want to work in partnership with our customers to evaluate their needs and develop cost-effective solutions. As a privately owned company, Conax is dedicated to improving customer satisfaction through continual improvement.

Turn to Conax first to share in these outstanding benefits:

- **On-Time Shipping** – reduces inventory & overhead, facilitates project scheduling
- **Quality Assurance** – eliminates need for receiving inspection & reduces assembly time
- **Competitive Pricing** – expedites order placement & reduces vendor search time
- **Engineering Support** – application knowledge & design capability
- **A Working Partnership** – we work with you to reduce your stress and product cost
- **In-house Capabilities** – full manufacturing, design and testing capabilities in our state-of-the-art production facility



2300 Walden Avenue
Buffalo, New York 14225
FAX: 716-684-7433 • Phone: 716-684-4500
1-800-223-2389
e-mail: conaxbuf@conaxbuffalo.com

European Office
PO Box 91
BOGNOR REGIS PO22 7JB, England
FAX: +44 1243 773050 • Phone: +44 1243 784060
e-mail: cbteurope@conaxbuffalo.com

www.conaxbuffalo.com • **www.partsdrawer.com**

Conax Buffalo Technologies is a registered trademark of Conax Buffalo Technologies.
Teflon is a registered trademark of E.I. DuPont de Nemours Company. • Kapton is a registered trademark of DuPont Films. • ISO certification refers to Buffalo location.