

Exhaust Gas Thermocouples

362A1102



Product Features and Benefits

- Superior quality
- Hermetically sealed for high accuracy and long life
- Simple quick installation saves time
- Talented technical support
- Parts are usually in stock to provide quick turnaround time

Conax Technologies' hermetically designed exhaust gas thermocouple has been field tested and proven to be more reliable than other suppliers' products for Frame turbine applications. This 100% hermetic thermocouple also has the latest more compatible materials to help eliminate open circuits during start up, thus eliminating false turbine trips and inconvenient and expensive down times. Our new exhaust gas thermocouple has been subjected to rigorous qualification tests including vibration testing to 10 million cycles of simulated on turbine operation, thermal cycling the measuring tip 20,000 times between 1220°F (660°C) and room temperature, and thermal cycling the hermetic terminal head 600 times between 700°F and -65°F (370°C and -54°C), passing all OEM qualification tests and meeting all design specifications required by the OEM. Our unit is manufactured with an all welded construction that is superior to brazing in prolonging the life of the thermocouple. This thermocouple is a direct replacement for all other exhaust gas thermocouples on Frame turbines, whether you are replacing or upgrading your equipment. They may be purchased directly from Conax Technologies to lower your total cost of ownership.

Superior Quality

These type K ungrounded thermocouples are manufactured using conductor materials meeting special limits of error ($\pm 0.4\%$ accuracy), and have a time response of 2.9 seconds. All specification qualified exhaust gas thermocouples are manufactured per ASTM standards utilizing the highest purity insulation materials yielding superior insulation resistance at elevated temperatures. Conax thermocouples are manufactured and tested at various points during the manufacturing cycle to give you the highest possible level of quality. The testing includes helium leak testing of sealing points, calibration, thermal shock and insulation resistance.

Precise Installation

Conax exhaust gas thermocouples are designed to ensure proper installation every time. The bushing at the sensing end of the thermocouple seats firmly into the radiation shield allowing the junction to be in the proper position, giving you the optimum response time and accurate temperature measurement. The bushing is also fabricated of materials that reduce the possibility of seizure in the radiation shield. The cold end features a ceramic insulated junction box using two different size studs to guarantee proper installation every time. It also enables a convenient, stress-free orientation of the thermocouple junction box as it relates to the mating cable by using a compression fitting.

Technical Sales Support

Whether you are upgrading or replacing your exhaust thermocouples, Conax Technologies' Technical Team can help you solve your problems. We can help you upgrade from using the one piece design such as the 302A4010Pxxx or 351A3488Pxxx or if you just need to replace a 362A1102 exhaust gas thermocouple. Call our inside Sales Team at +1 716 684 4500 and you'll get the support you need to make the right choices.



Ideas. Solutions. Success.

+1 716 684 4500

+1 800 223 2389

Conax@ConaxTechnologies.com

Dimensional Features

Hermetic Exhaust Gas Thermocouple Model 362A1102

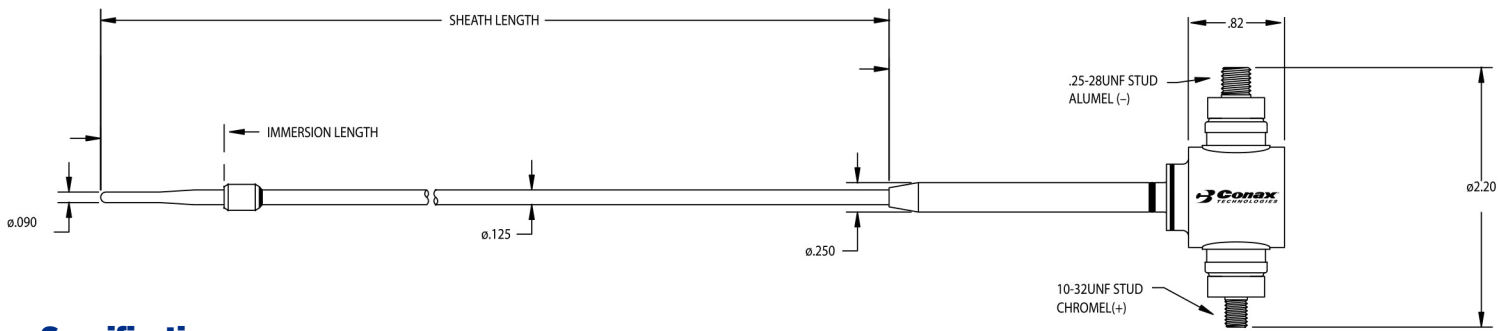

Specifications

Calibration:

- Type K, Chromel Alumel®
- ± 0.4% accuracy (special limits of error)
- Meets the requirements of ASTM E585 and ASTM E608

Insulation Resistance:

- 1×10^9 ohms @ 50 VDC

Time Response:

- 2.9 seconds

Hermetic Seal:

- 1×10^{-6} ssc/sec He for the entire thermocouple

Sheath Diameter:

- 0.125" (3.2mm)

Environmental Ranges:

- -20° to 700°F (-29° to 371°C) at the termination
- -20° to 392°F (-29° to 200°C) for the cable
- 100% humidity for the entire thermocouple

Applications:

- Frame turbines

Related Products:

- Enhanced Exhaust Gas Sensors—Bulletin 6054E
- Hermetic Exhaust Gas Thermocouple—Model 351A3488 Bulletin 6052
- Bearing Sensors: Bulletin 6035
- Hermetic Wheelspace Thermocouples—Model 361A2289 Bulletin 6053
- Bearing Sensor Wire Seals: Catalog 5001
- RTDs/Thermocouples: Catalog 5005

Also Available from Conax Technologies

- Radiation shields—Model 362A1344Pxxx
- Mating cables—Model 361A2327Pxxx

For more information about Conax Technologies, visit conaxtechnologies.com.

2300 Walden Avenue, Buffalo, New York 14225
+1 800 223 2389 (P) | +1 716 684 7433 (F)
conax@conaxtechnologies.com  Made in U.S.A.
Bulletin 6054, Rev D ©2020 Conax Technologies 11/20

Conax
TECHNOLOGIES
Ideas. Solutions. Success.



ConaxTechnologies.com