

LM6000 Series Exhaust Gas Thermocouple

For land-based power generation applications



High-quality, cost-effective solution

Conax Technologies has introduced a cost-effective solution for LM6000 Series exhaust gas temperature measurement applications.

Conax has a proven history of manufacturing reliable temperature sensors for large frame gas turbines and aeroderivative engines and now offers an aftermarket equivalent for LM engines.

The Conax LM6000 Series exhaust gas sensors are engineered from state-of-the-art materials that are fully interchangeable with OEM products and offer excellent mechanical strength and superior oxidation creep resistance. The Conax solution is available at a competitive price point for all LM ground-based turbines.

Product Features and Benefits

- Conax uses state-of-the-art materials to achieve mechanical strength and oxidation resistance.
- The Conax Hermetic termination head utilizes type K termination studs that are sized so cables cannot be cross wired.
- The Conax solution is interchangeable with OEM products, so it can be used on all LM6000 Series applications.
- The over sheath is made from state-of-the-art material sized for proper fit around the thermocouple tip. The Conax design does not require special shims that can vibrate loose.



Ideas. Solutions. Success.

LM6000 Series Exhaust Gas Thermocouple

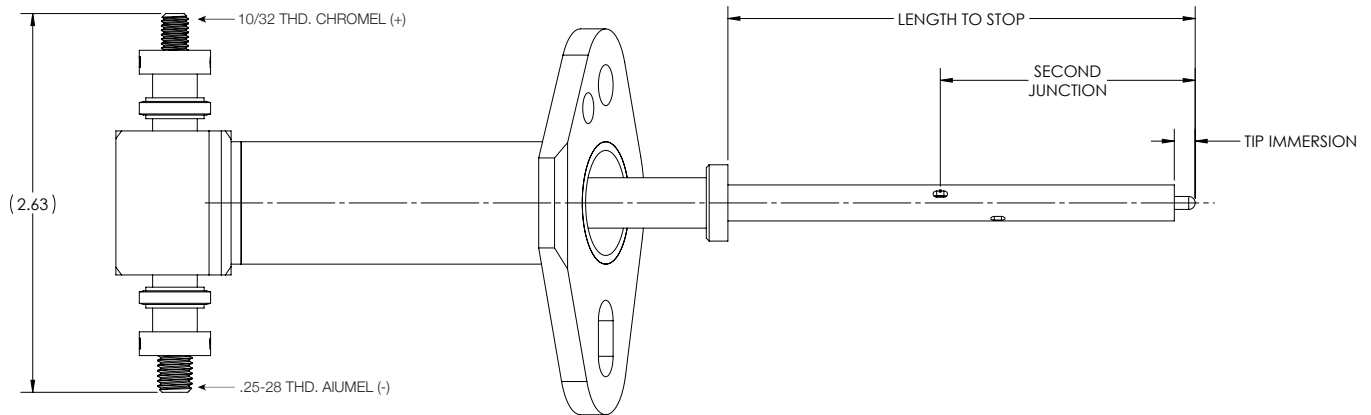

Specifications

Calibration:

- Type K
- + 0.4% accuracy (special limits of error)
- Dual staggered junction

Insulation Resistance:

- 1×10^8 ohms @500VDC

Dielectric Strength Test:

- 5mA allowable leakage at Voltage: 300 VAC

Hermetic Seal:

- 1×10^{-6} scc/sec He for the entire thermocouple

Environmental Ranges:

- -20° to +800°F (-29° to +426°C) at the termination head
- -20° to +392°F (-29° to +200°C) at the mating cable
- 100% Humidity for entire sensor

Application:

- Ground-based turbines (not for flight use)

Related Products:

- Mating Cables

Also available from Conax:

Large Frame Sensors

- Frames 5, 6, 7—Bulletin 6052
- Frames 6, 7— Bulletin 6053
- Frames 6, 7, 9—Bulletin 6054
- Frame LM6000—Bulletin 6105

2300 Walden Avenue, Buffalo, New York 14225
+1 800 223 2389 (P) | +1 716 684 7433 (F)
Conax@ConaxTechnologies.com

Bulletin 6121, Rev E ©2024 Conax Technologies 4/24

Conax
TECHNOLOGIES
Ideas. Solutions. Success.